

# **DECT Modem**

**Datasheet**

**(Rev. 1.1)**

**Peucon**

**GmbH**



# Directory

**DIRECTORY** ..... 1

**DECT MODEM** ..... 3

    Mode-Types: ..... 3

    DEFAULT-SETTINGS SIEMENS DECT ENGINE MD3X ..... 3

    LOG-ON PROCEDURE OF DECT-PARTS WITH EACH OTHER ..... 4

        Configuration as V24 Replacement PP and log-on ..... 4

        Configuration as V24 Replacement FP and log-on ..... 5

        Store configuration in profile ..... 6

**DECT PLUG A2**..... 7

    Technical Data: ..... 7

**DECT PLUG B1**..... 10

    Technical Data: ..... 10

**DECT SWITCH** ..... 13

    SWITCH MODE ..... 13

    RS232 PLUG MODE ..... 14

    SUMMARY OF FUNCTIONS: ..... 15

    LED'S - DESCRIPTION ..... 17

**DECT RADIO NETWORK REPEATER (DECT RNR)** ..... 18

    VOLTAGE SUPPLY: ..... 20

    CONFIGURATIONS: ..... 20

    RS232 CONFIGURATION: ..... 20

    DESCRIPTION OF LED'S: ..... 21

    SYSTEM SET-UP WITH THE DECT RNR ..... 21

**DECT - LINE - MODEM**..... 26

    APPLICATION FIELD ..... 26

    MECHANICAL DESIGN ..... 27

    SPECIAL ADJUSTMENTS FOR THE LINE-MODEM ..... 28

    CURRENT PROBLEMS AND RESTRICTIONS OF THE DECT-LINE-MODEM ..... 29

    USER GUIDE SINGLE CHIP MODEM ..... 29

**THE MOST IMPORTANT COMMANDS** ..... 30

    Basis configuration ..... 30

    Flow Control-Settings (Handshake) ..... 31

    Setting of the baud rate ..... 31

    Register setting / enquiry ..... 32



---

Datasheet

Set configuration profile.....	33
Configuration in Profile store / delete .....	33
Log-on of PPs to a FP (Command for FP).....	34
Log-on of PPs to a FP (Command for PP).....	35
<b>INSTRUCTIONS OF USE MD3X .....</b>	<b>36</b>



## DECT Modem

There are three different versions of the DECT Modem: DECT Plug A2, DECT Plug B1, DECT Switch and DECT RNR. All three versions are based on the DECT

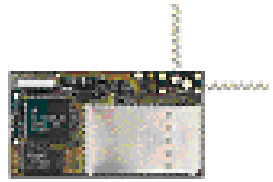

Engine MD32 data radio module from the firm Siemens. All DECT Modems have a range of approx. 300 m in the open air and 50 m within buildings. Each version possesses an internal aerial and a casing made of impact-resistant polystrol (light grey / agate grey). Measurements (L x W x H): 125 x 67 x 32 mm. A wall mounting bracket is available optionally.

### Mode-Types:

The Siemens DECT Engine MD3x has 2 different mode-types:

**Data-Mode:** When in this condition the MD3x is transparent for the data interface. It is a cordless cable extension. It is possible to enter the command mode over the escape sequence.

**Commando-Mode:** When in this mode no data can be transferred. Configurations can take place over all AT-commands. To return again to the data mode the command "ATO" must be entered and then return must be pressed.

### Default-Settings Siemens DECT Engine MD3x

The configuration takes place over AT-commands. For this a terminal-programme is required (e.g. HyperTerminal). During the configuration flow control may not be set in the terminal programme.



### Connection Set-ups:

Bits per second: 19200 Baud  
Data bits: 8  
Parity: None  
Stopbits: 1  
Protocol: None  
Escape-Sequence: +++

### Log-On Procedure of DECT-Parts with each other

The configurations remain in the case of a power failure.

*Tip:* The sign ↵ indicates the return key.

### Configuration as V24 Replacement PP and log-on

Input	Output	Description
+++	OK	Change to command mode
AT^SBASC1↵	MD32	The PP is configured as a V.24 Replacement. A re-start then takes place.
+++	OK	Change to command mode
ATS190=0↵	OK	Choice of a log-on sentence
ATS191=0↵	OK	Deletion of the log-on sentence



Input	Output	Description
AT^SOAC0000,0↵	WAIT / Error / OK	Start log-on procedure. The log-on procedure must be simultaneously active in both plugs. The log-on takes place through the air. In case of a successful log-on OK must be indicated on both sides. If an error has occurred then ERROR is indicated. A reattempt can first be started when both plugs have acknowledged. The "WAIT" state can be terminated by the sending of any symbol.
ATO↵	OK	Change to data mode

### Configuration as V24 Replacement FP and log-on

Input	Output	Description
+++	OK	Change to command mode
AT^SBASC0↵	MD32	The FP will be configured as a V 24 Replacement. A restart then takes place.
+++	OK	Change to command mode
ATS190=0↵	OK	Choice of a log-on sentence
ATS191=0↵	OK	Deletion of the log-on sentence

**Datasheet**

<b>Input</b>	<b>Output</b>	<b>Description</b>
AT^SENB0000,0↵	WAIT / Error / OK	Start log-on procedure. The log-on procedure must be simultaneously active in both plugs. The log-on takes place through the air. In case of a successful log-on OK must be indicated on both sides. If an error has occurred then ERROR is indicated. A reattempt can first be started when both plugs have acknowledged. The "WAIT" condition can be terminated by the sending of any symbol.
ATO↵	OK	Change to data mode

## Store configuration in profile

The configuration can be stored in profile 1 to 4. The following table is an example of profile 1:

<b>Input</b>	<b>Output</b>	<b>Description</b>
+++	OK	Change to command mode
		Change of settings
AT&W-1↵	OK	Deletion of profile 1
AT&W1↵	OK	Storing of profile 1
AT&F1↵	OK	Loading of profile 1
ATO↵	OK	Change to data mode



# DECT Plug A2

The DECT Plug A2 is a cordless RS232 data radio connection. The DECT Plug A2 has a serial interface and an external power supply.



## Technical Data:

RS232:	<p>9-pole D-Sub-jack for the connection to the COM-interface of a PC.</p> <p>RS232-Transmission rate: 9.6 until 115.2 kBit/s</p> <p>RS232-Flow control: none XON/XOFF Hardware (RTS/CTS)</p>
DECT-Radio:	<p>According to DECT Standard: Approx. 1880 ... 1900 MHz</p> <p>Transmission: 250mW ( +24dBm)</p> <p>Receiver -sensitivity: &lt; -86 dBm</p> <p>Internal aerials: 2</p> <p>Range: open air approx. 300 m in buildings approx. 50 m</p>



Datasheet

Power:	DC-jack 2.1/5.5mm for connection of a network plug to the power supply.  Voltage: 9 VDC not stabilized Current consumption: max. 100 mA with an active connection, max. 200 mA with four active data connections
Light-emitting diode:	On: Power supply on RS232: RS232-module active Rx: PC receives data from radio module Tx: PC transmits data to radio module Lock: Radio connection exists (PP is locked on to FP)
Casing:	Measurements 125 x 67 x 32mm, the casing is made of shock-proof polystyrol, light grey/agate grey.
Temperature range:	0 ...+40°C



<p>DECT Radio module MD32:</p>	<p>Three operating modes can be set:</p> <ul style="list-style-type: none"><li>V.24 Replacement PP (Portable Part)</li><li>V.24 Replacement FP (Fixed Part)</li><li>V.24 Server FP (Fixed Part)</li></ul> <p>For a point for point data transmission one module must be configured as a terminal device (V.24 Replacement PP, portable part), and a second as a basis station (V.24 Replacement FP, fixed part).</p> <p>Configuration of the module over AT command. Four different configurations are storable. The terminal device can log itself onto six basis stations. The logging on of up to 16 terminal devices onto one basis station is possible. The basis station configured as a V.24 Server FP can serve up to 16 RS232 connections of which 4 can be simultaneously active. Automatic setting-up and dismantling of the connection is dependent on data traffic. Internal error correction protocol guarantees a bit error rate of <math>&lt; 10^{-8}</math>.</p> <p>Certified according to the DECT-Standard CTR6.</p> <p>Secure data transmission over a reserved frequency band, data saving protocol (LU10 Standard) as well as data encryption.</p>
--	--



## DECT Plug B1

The DECT Plug B1 is a cordless RS232 data radio connection for connection to the USB-Port of your PC. The device will be connected to the USB on your PC. The DECT Plug B1 is laid out as a full speed device with a maximum data transmission rate of 12 MBit/s (USB-Version 1.1). The ready status of the device is indicated over an LED. The USB connection will be addressed as a COM-interface(virtual COM-Port) and also configured as a COM interface. The maximum data transmission rate is 115.2 kBit/s.

The DECT USB Plug B1 is especially suitable for mobile usage with notebooks in sales and storekeeping. By simply plugging in to the USB plug a radio connection is made available without using any additional power. An example is the controlling of stocks with the PocketScan (barcode scanner with built-in radio module).



### Technical Data:

USB:	Version 1.1, Full Speed, 12Mbit/s USB-B-jack for connection to the USB-interface of a PC / Laptop.
------	---



DECT – Radio:	According to DECT Standard: approx.1880 ... 1900 MHz Transmission: 250mW ( +24dBm) Receiver -Sensitivity: < -86 dBm Internal aerials: 2 Range: open air approx. 300 m in buildings approx. 50 m
Power:	5 VDC from USB-Bus, Low Power-device Current consumption: max. 100 mA with an active connection max. 200 mA with four active data connections <b>Optional:</b> DC-jack 2.1/5.5mm for connection of plug-in power supply with four active data connections
Light-emitting diodes:	On: Power supply on USB: USB-Bus active Rx: PC receives data from radio module Tx: PC transmits data to radio module Lock: Radio connection exists (PP is locked on to FP)
Casing:	Measurements 125 x 67 x 32mm, the casing is made of shockproof Polystyrol (light grey / agate grey).
Temperatur-range:	0 ...+40°C





## DECT Switch

The DECT Switch is intended for mounting in a switcher box. With a width of 75mm the DECT Switch can be clipped onto the DIN bar. For radio connection the MD32 from Siemens AG is integrated. The mounting in a protective casing is made possible by the connection to external aerials. The operational modes Switch and



RS232 Plug can be selected by use of the mode switch. The DECT Switch can be operated at temperatures of 0°C - 40°C. The configuration takes place over the RS232-interface using AT-commands.



### Switch Mode

In the Switch Mode two contact states can be transmitted both-way over radio. The hardware for the alarm transmitter and the contact transmitter is identical. The DECT Switch is configured over the RS232-interface. The alarm transmitter is a DECT V.24 Replacement PP (Portable Part). The contact transmitter is a V.24 Replacement FP (Fixed Part).

The contact transmitter and the alarm transmitter receive a mutual radio connection over a log-on procedure. The input condition from the contact transmitter of In1/In2 is transmitted directly to the alarm transmitter and put out on the output Out1/Out2. The out master controls the operating states. Example of an application:

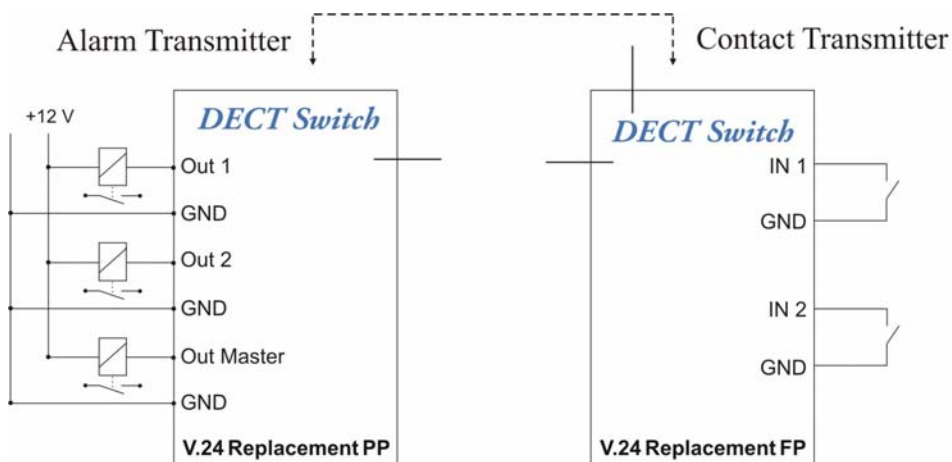

## RS232 Plug Mode

In this mode the DECT Switch works as a normal RS232 DECT modem. In RS232 Plug Mode the switch can work together with DECT Plug A2 or DECT Plug B1. The operational mode V.24 Replacement FP / PP or V.24 Server FP is possible.



## Summary of Functions:

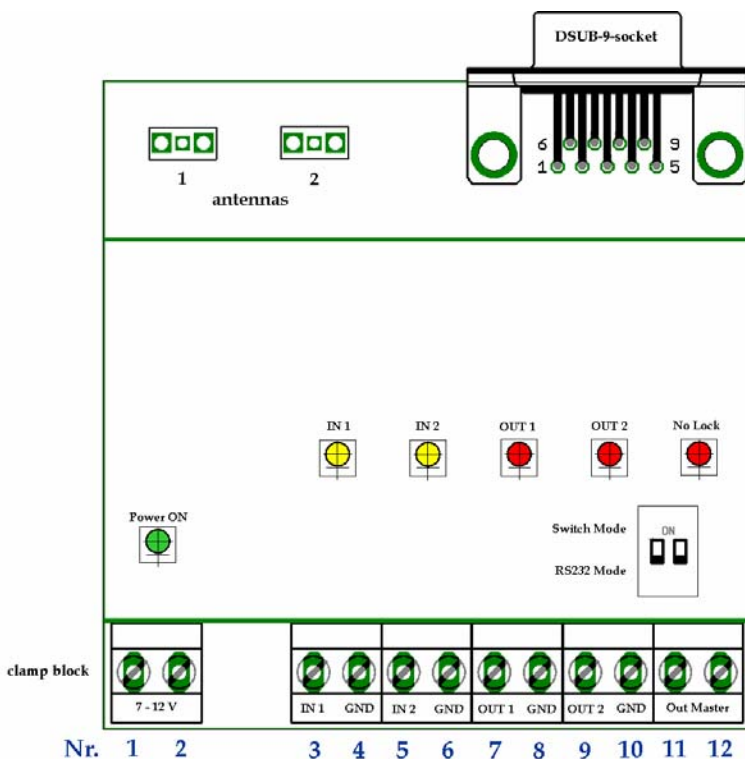

Name	Nr.	Connection	Explanation	RS232	Switch
-	-	-	If there is no connection for 5 seconds, the out master is set on Low.	●	●
Power 1	1	Terminal	Voltage supply 7 to 12 V suitable for direct current or alternating current. Reverse connect protection. The maximum current consumption is 150 mA.	●	●
Power 2	2				
In 1	3	Terminal	State of this input 1 is transmitted to the output Out 1 of the partner-Switch (potential-free switching In1 according to GND (Low)).		●
GND	4				

**Datasheet**

<b>Name</b>	<b>Nr.</b>	<b>Connection</b>	<b>Explanation</b>	<b>RS232</b>	<b>Switch</b>
In 2	5	Terminal	State of this input 2 is transmitted to the output Out 2 of the partner-Switch (potential free switching In1 according to GND (Low)).	●	●
GND	6				
Out 1	7	Terminal	The state of In1 of the partner-Switch is transmitted to output 1. The output consists of OC transistors at GND (low-level is +1.1 V, high-level is external voltage max. +12 V with maximum current of 100 mA).		●
GND	8				
Out 2	9	Terminal	The state of In 2 of the partner-Switch is transmitted to output 2. The output consists of OC transistors at GND (low-level is +1.1 V, high-level is external voltage max. +12 V with maximum current of 100 mA).	●	●
GND	10				
Out Master	11	Terminal	The output master is active if the radio connection is interrupted. The controlling of the radio connection is only optimal in the Portable Part (PP). The output consists of OC-transistors at GND (low-level is +1.1 V, high-level is external voltage max. +12 V with maximum current of 100 mA).		●
GND	12				
Aerial 1	1	Aerial	Aerial connection for Fixed Part (FP) or Portable Part (PP)	●	●
Aerial 2	2	Aerial	Aerial connection for Fixed Part (FP)	●	●
RXD	2	D-SUB 9	Output for RS232 data	●	●
TXD	3	D-SUB 9	Input for RS232 data	●	●
GND	5	D-SUB 9	Mass for RS232	●	●
CTS	8	D-SUB 9	Output for RS232 hardware flow control	●	
RTS	7	D-SUB 9	Input for RS232 hardware flow control	●	



## LED's - Description

Name	Nr.	LED
-	-	No Lock Illuminates if no radio connection exists ( red ).
Power 1	1	Illuminates if voltage is existent (green ).
Power 2	2	
In 1	3	Illuminates if In 1 GND has potential ( yellow ).
GND	4	
In 2	5	Illuminates if In 2 GND has potential ( yellow ).
GND	6	
Out 1	7	Illuminates if Out 1 GND has potential ( red ).
GND	8	
Out 2	9	Illuminates if Out 2 GND has potential ( red ).
GND	10	

# DECT Radio Network Repeater (DECT RNR)

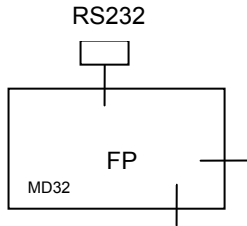

### Konfiguration des FP und RNR-FP über RS232-Schnittstelle:

- „+++“ Eingabe zur Konfiguration des FP
- „---“ Eingabe zur Konfiguration des RNR-FP

Die Lock-LED muss leuchten !

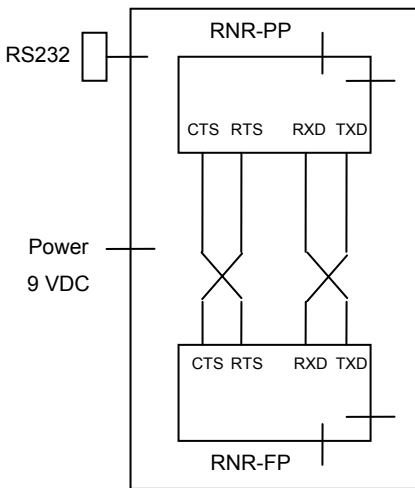

### Konfiguration des RNR-PP über RS232:

- „---“ Eingabe zur Konfiguration des RNR-PP

Die Lock-LED muss aus sein!

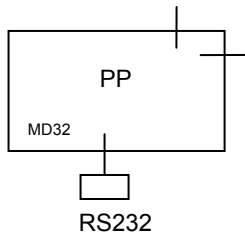

### Konfiguration des PP über RS232:

- „+++“ Eingabe zur Konfiguration des PP



The DECT Radio Network Repeater (DECT RNR) is an extension of a cordless RS232 data radio connection. The device has a serial interface for configuration, an internal aerial and an external power supply. The data transmission rate is 115.2 kBit/s.

The DECT Radio Network Repeater consists of two Siemens DECT Engine MD32 modules. The module was configured as a PP to a RNR-PP. The other one was configured as a FP to a RNR-FP. The RNR transmits the control lines RTS/CTS and the data lines TxD and RxD. Further RS232 control lines are not transmitted.



The RS232-interface serves the configuration of the RNR-PP. The RNR-FP is configured over the radio link which means that also when in the installed condition further PPs can be logged on and off. The RNR-FP only transmits if the RNR-PP has a connection to the FP. When the RS232 is off in relation to the RNR-PP, data which is transmitted from RNR-PP to RNR-FP can still be viewed on the RS232. The configuration of the RNR-PP over the RS232-interface can only take place if the RNR-PP is not locked on to an FP. If the RNR-PP has to be configured then the appropriate FP must be switched off. Normally the RNR-PP as well as the RNR-FP have the "ESC"-symbol set on „-“.

The RNR-PP must always be set as a V.24 Replacement. The RNR-FP can be operated as a V.24 Replacement or a V.24 Server. The RNR has internal aerials which are in the area of the LEDs. Therefore it is advantageous when mounting to fit them vertically.



## Voltage Supply:

DC voltage 9V. Minimum 250mA is necessary for a radio connection. In the server-mode with four connections 400mA are necessary. The outer contact at the plug is "GND", the internal contact is "+".

## Configurations:

At delivery the following configurations are carried out which deviate from the MD32-configuration:

Command	Description
ATS158=0 ↘	Permanent radio connection
ATIQ2 ↘	Flow control=Hardware (RTS/CTS)
ATS2=45 ↘	ESC-symbol = "-" with „--„ in command mode
AT&W-1 ↘	Deletion of profile Nr.1
AT&W1 ↘	Storing of profile Nr. 1
AT&F1 ↘	Loading of profile Nr. 1
ATO ↘	Leave commando mode

## RS232 Configuration:

Bits/s: 19200  
Databits: 8  
Parity: None  
Stopbits: 1  
Protocol: Hardware



### Description of LED's:

Name	Meaning (Illumination of LED)
ON	Voltage supply is available over the plug-in power supply
FP-LOCK	A PP has a connection with the RNR-FP for the first time
RX	Data is transmitted from RNR-PP to RNR-FP.
TX	Data is transmitted from RNR-FP to RNR-PP.
PP-LOCK ( RS232 OFF )	The RNR-PP has a connection to the FP. The RS232-interface is deactivated. The RNR-FP is transmitting

### System set-up with the DECT RNR

#### Step 1:

Log-on of the RNR-PP to the FP:

Input at FP	Input at RNR-PP	Message from Module	Description
switch-on of the power supply		MD32: Replacement FP	



Datasheet

Input at FP	Input at RNR-PP	Message from Module	Description
	switch-on of the power supply. As long as the RNR-PP is not logged on, then the RS232-interface is active.	MD32: Replacement PP	
+++		OK	
	---	OK	
ATS158=0		OK	Permanent radio connection
AT^SENB0000,0		WAIT	
	AT^SOAC0000,0	WAIT	
		OK / ERROR	
After successful log-on turn the power supply off!			
ATS189=0		WAIT	Selection of the PP
		OK / (ERROR)	
	ATS189=0	WAIT	Selection of the FP
		ERROR / (OK)	
	AT\Q0	OK	Handshake Off
	AT&W-1	OK	Deletion of profile Nr. 1
	AT&W1	OK	Storing of profile Nr. 1
	AT&F1	OK	Loading of profile Nr. 1



Input at FP	Input at RNR-PP	Message from Module	Description
Turn the power supply off			
	Turn the power supply off.		

**Step 2:**

Log-on of the PP to the RNR-FP:

Input at FP	Input at PP	Message from Module	Description
switch-on the power supply at FP		MD32: Replacement FP	
switch-on power supply at RNR		MD32: Replacement FP	
	switch-on the power supply	MD32: Replacement PP	
---		OK	
	+++	OK	
	ATS158=0	OK	Permanent radio connection
AT^SENB0000,1 (1 to 5)		WAIT	
	AT^SOAC0000,1 (1 to 5)	WAIT	
		OK / ERROR	



Datasheet

Input at FP	Input at PP	Message from Module	Description
ATS189=1 (1 bis 5)		WAIT/OK	
ATO			
	ATS189=1 (1 bis 5)	WAIT/ERROR	Selection of the FP
	ATO		

**Step 3:**

Configuration RS232 RNR-PP

Input at FP	Input at RNR-PP	Message from Module	Description
switch-off power supply		MD32: Replacement FP	
	switch-on power supply. As long as the RNR-PP is not logged on then the RS232-interface is active	MD32: Replacement PP	
	Connect the RS232 cable		
	---	OK	
	AT\Q2	OK	Handshake On
	AT&W-1	OK	Deletion of profile Nr.1



Input at FP	Input at RNR-PP	Message from Module	Description
	AT&W1	OK	Storing of profile Nr.1
	AT&F1	OK	Loading of profile Nr.1
	switch-off power supply		

## DECT - Line - Modem

The DECT - Line - Modem is an interface between a DECT device and an analog telephone line. It has a transmission rate of 1200 Bit/s or 2400 Bit/s. The range between DECT application and telephone line is approx. 300 m in the open air and 50 m within buildings. The DECT - Line - Modem contains a Telephone - A/B - Line - Modem and a DECT Data Module MD32. Both modems can be configured by means of AT-commands.

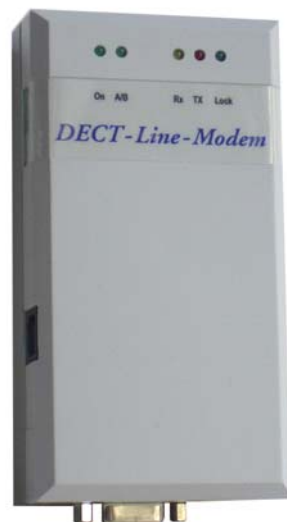

## Application Field

- **Outgoing and incoming calls**

Data can be transmitted or received without having to relocate telephone lines or other cables.

- **Modem**

The DECT - Line - Modem can be used as a normal modem e.g. data from a hand scanner can be sent over radio to the head office or to the merchant.

- **Production data aquisition**

One of the main usages is the remote collection of electronic readings of electricity, water and gas in private households. Additionally the query of operating states of remote working production machines can be carried out.

- **DTMF**

DTMF - tones are available both way and can be processed in the system. Thus a remote control of the system is possible with the necessary software.

- **SMS**

It is possible to send short messages to the fixed network. The support of the network operating company is necessary for this.



o **Caller ID**

The DECT - Line - Modem is 'Caller ID' compatible which means that incoming call numbers can be displayed assuming this is supported by the caller and the network operator.

## Mechanical design

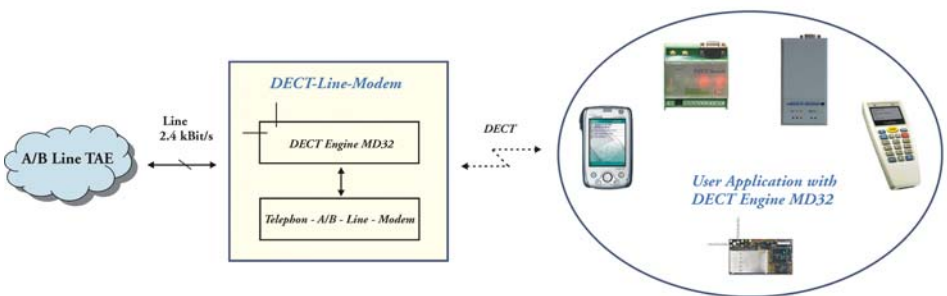

The data is first transmitted from the DECT device to the DECT - Line - Modem and transferred further to the Telephone-A/B-Line-Modem. In the Telephone-A/B-Line-Modem the data is converted into analog data and transferred further over an A/B-telephone line. The other transmission direction is analog. All devices with an integrated DECT engine MD32 radio module are suitable as DECT devices e.g. PocketScan, DECT Plug A2, DECT Plug B1 from Peucon GmbH.

Using AT-commands adjustments can be made e.g. the changing of parameters in the telephone network according to the appropriate country, the dialling of numbers or the answering of calls. In the Line-Modem the telephone adjustments of many countries or rather the standards are pre-programmed. But adjustments can also be made for other standards specifically for the user. An EU accreditation is in preparation.



The casing consists of impact-resistant polystyrol. The measurements (H x W x D) are 125 x 67 x 32 mm. A fixing element for wall mounting can be received optionally.

## Special Adjustments for the Line-Modem

### Kommando-Mode

Kommando-Mode: '\* \* \* '

### DECT - Line - Modem – Initialisation

ats51=10s53=10s95=\$10s123=\$64s21=\$11x3k3

or

ats51=10

ats53=10

ats95=\$10 enables CID

ats123=\$64 soft ring detect

ats21=\$11 Flow - Control: RTS/CTS, DTR active and  
keypress abort enable

atx3 no wait for dialtone

atk3 Flow - Control: RTS/CTS

Dial with atdt<NUMMER>

### Access over RS232

Access over RS232 is only possible if the DECT-Line-Modem is not locked onto the PP.



## **Current Problems and Restrictions of the DECT-Line-Modem**

The following problems or restrictions are currently contained in the DECT-Line-Modem:

- At the moment incoming calls are not yet recognised.
- The extension lines in the TAE-N – box a1 and b1 are not currently supported.
- Hardware–Handshake is not functioning correctly, a maximum of 42 Bytes can be transmitted consecutively. After that one must wait until the intermediate memory has been transmitted from the chip. Incoming data from the telephone network are transferred correctly.

## **User Guide Single Chip Modem**

The User Guide for the TDK 73M2901CE also belongs to this manual concerning the DECT – Line – Modem. The User Guide is available at the Peucon GmbH.



## The most important commands

The configurations remain after a power-cut.

**Tip:** The symbol  symbolises the return key.

Input	Parameter	Description
+++	-	This is the escape-sequence. When entered a change is made into command mode. The time between every "+"-input must be 1 second.
ATO 	-	Change to the data-mode.

## Basis configuration

Input	Parameter	Description
AT^SBASC 	conf_type (0 ... 3)	<p>Changes the basis configuration, deletes and boots the corresponding SW image. A restart takes place. E.g. With the command AT^SBASC1 the PP is configured as a V.24 Replacement PP.</p> <p><b>conf_type = 0</b> → "V.24 Replacement FP" <b>conf_type = 1</b> → "V.24 Replacement PP" <b>conf_type = 3</b> → "V.24 Server FP"</p> <p>The basic setting is 1.</p>



## Flow Control-Settings (Handshake)

Input	Parameter	Description
AT\Q[]	flow_ctrl (0.-.2)	Sets the flow control method (Handshake) for the data transfer.  <b>flow_ctrl = 0</b> -> No flow control <b>flow_ctrl = 1</b> -> XON/XOFF <b>flow_ctrl = 2</b> -> RTS/CTS  The default setting is 0.

## Setting of the baud rate

Input	Parameter	Description
AT\R[]	baud rate	Sets the V.24 data transfer rate.  Only in command status <b>baud_rate = 5</b> -> 9600 Baud <b>baud_rate = 7</b> -> 19200 Baud  The default setting is 7.



## Register setting / enquiry

Input	Parameter	Description
ATS189=[ ]↵	(0..5), (0..15)	The corresponding part is selected with which a connection is to be made. The selection takes place through the setting of the number of the log-on sentence. If the command is put in at the PP, then the FP is selected with the Nr. 0..5. If the command is put in at the FP then the PP with the PP Nr. 0..15 is chosen.
ATS190=[ ]↵	(0..15), (0..5)	Choice of a log-on sentence for deletion (0..15) stands for PP1..PP16 and (0..5) stands for FP1..FP6.
ATS191=0↵		The selected log-on sentence will be deleted
ATS158=[ ]↵	(0..255)	A timeout is set. After the indicated time the connection is broken if no more data is transmitted. The parameter value 0 stands for a permanent radio connection. The parameter value 1..255 means a timeout of 1..255 seconds.
ATS2=45↵		Set escape sequence to „-„. This is necessary for example for the repeater configuration. This adjustment must be stored in the profiles.
ATS[ ]?↵	(189 191)	The values of the registers (189-191) will be inquired. If ATS191?↵ shows a 1 then the log-on is active a 0 means non-active.



## Set configuration profile

Input	Parameter	Description
AT&F[ ] [ ]	profile_num (0...4)	MD32 sets configuration profile. Only possible in command mode. With the "profile_num" parameter it is possible to select a special configuration profile. If no parameter or 0 is selected then the basic settings are used.

## Configuration in Profile store / delete

Input	Parameter	Description
AT&W[ ] [ ]	profile_num (1...4) (-1...-4)	Stores the current parameter values in the profile "profile_num". "-1" means deletion of the profile "profile_num".



## Log-on of PPs to a FP (Command for FP)

Input	Parameter	Description
AT^SENB[,]↵	pin, (4 digits) subsc_index (0 - 15)	<p>Only with FP (V.24 Replacement FP and V.24 Server FP) possible. Serves the logging-on of portable parts to the FP. The Pin is a 4 digit number which is only needed during the log-on procedure. The Pin must be identical for the FP and the PP during the log-on procedure. The subsc_index (subscription index) is the index of the log-on sentence. With this index the identification of the PPs will take place. This number will also be required for the selection of the PPs over the command AT\$189=subsc_index required.</p> <p>If the procedure was successful then Wait will come and then OK.</p> <p>If Wait remains for 10 minutes and then Error comes then the procedure was unsuccessful. If Error is indicated immediately then no log-on position is free.</p> <p>A reattempt can first be carried out when both plugs have acknowledged. The " WAIT" condition can be interrupted by the sending of any symbol</p>



### Log-on of PPs to a FP (Command for PP)

Input	Parameter	Description
AT^SOAC[.,]↵	pin, (4 digits) subsc_index (0 - 5)	<p>Only possible with PP (V.24 Replacement PP). Serves the logging-on of portable parts to the FP. The Pin is a 4 digit number which is only required during the log-on procedure. The Pin must be identical for the FP and the PP during the log-on. The subsc_index (subscription index) is the index of the log-on sentence. With this index the identification of the PPs will take place. This number will also be required for the selection of the PP' over the command AT\$189=subsc_index required.</p> <p>If the procedure was successful then Wait comes and then OK. If Wait remains for 1minute and then error comes then the procedure was unsuccessful. If Error comes immediately then no log-on position is free. A reattempt can first be carried out when both plugs have acknowledged. The "WAIT" condition can be interrupted by the sending of any symbol.</p>



## Instructions of Use MD3x

The **Configuration Manager** displays status information as well as log-on and log-off procedures and also carries out firmware-updates of the DECT MD3x. After the programme start, the **Configuration Manager** first of all checks the PC's serial interfaces in order to determine if a DECT MD3x is present. After this the programme window should look approximately like this:

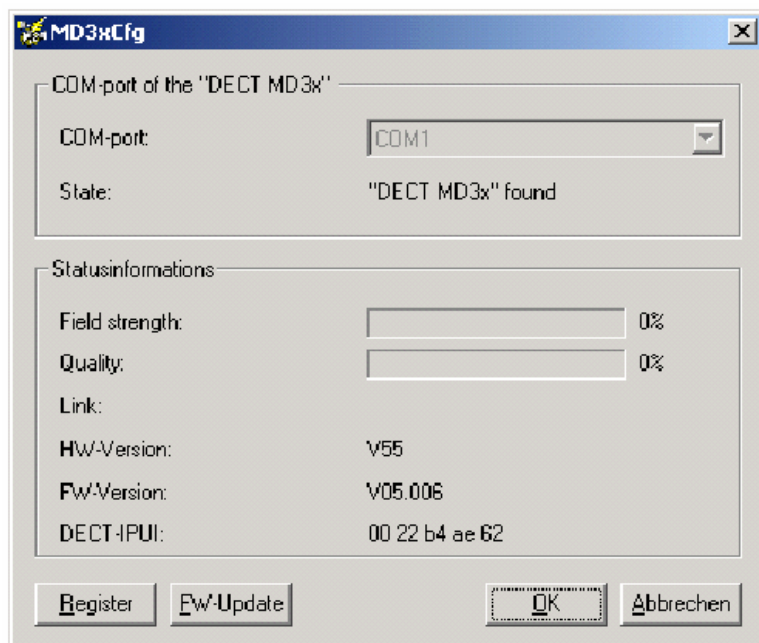

If a DECT MD3x is successfully identified then **connection of the "DECT MD3x" to the PC** is displayed in the field of the used interface connection and the interface status is displayed, otherwise the sentence emerges "no DECT MD3x could be found". Under **Status information** the field strength or rather the



network quality of the DECT radio connection is displayed graphically (0 bis 100%) as well as the connection status to the DECT distant terminal. Other than that information is provided on the hardware and firmware-version or rather DECT-IPUI DECT MD3x. With log-on/log-off, the DECT MD3x is logged on or off to a DECT base according to connection status. With **FW-Update**, the firmware of the DECT MD3x, an update can be carried out by opening the appropriate bin-data.







Datei: Datasheet-DECT Modem-eng5.doc

Stand: 25.11.2005

Peucon Unternehmensberatung &  
Entwicklung von Kommunikationstechnik GmbH

Gotenstraße 14

D-10829 Berlin

Tel: (+49)-(0)30-78 70 10 10  
Fax: (+49)-(0)30-78 70 10 13  
Email: [info@Peucon.com](mailto:info@Peucon.com)  
Internet: [www.Peucion.com](http://www.Peucion.com)

© 2005